



INVITATION TO BID

BID SOLICITATION DOCUMENT

General Bid Information

	Bid Number:	CAW# 22-32
	Description:	One (1) Service Body and One (1) Undercarriage, PTO Driven Air Compressor
	Solicitation Issued:	August 4, 2022

Submission Deadline for Bid Response

	Bid Opening Date:	Thursday, August 18, 2022	Bid Opening Time:	2:00 p.m., Central Time
	<p>Bid responses shall not be accepted after the designated bid opening date and time. It is the responsibility of vendors to submit bid responses at the designated location on or before the bid opening date and time. Bid responses received after the designated bid opening date and time shall be considered late and shall be returned to the vendor without further review. It is not necessary to return "no bids" to CAW.</p>			

Delivery Information for Bid Response

	Delivery Address:	<p>Central Arkansas Water ATTN: Purchasing Section 221 East Capitol Avenue Little Rock, AR 72202</p> <p>Delivery providers USPS, UPS, and FedEx deliver mail to CAW's street address on a schedule determined by each individual provider. These providers will deliver to CAW based solely on the street address.</p> <p>Note: For safety purposes, vendor(s) are encouraged to provide submissions electronically or mail with a delivery provider; however, vendors who choose to hand deliver a bid response, should contact the CAW Purchasing Section in advance to make delivery arrangements or during the current Coronavirus Pandemic, please call Bridgette Johnson at 501-377-1210 or David Hindman at 501-377-1315 before planned delivery at 221 East Capitol Avenue and someone will accept your bid.</p>
	Bid Response's Outer Packaging:	<p>Vendor's bid must be delivered to CAW in a sealed package. The outer packaging should be properly marked with the information listed below. (Traditional Method) If the packaging is not properly marked, it may be opened for bid identification purposes.</p> <ul style="list-style-type: none"> Bid number Date and time of the bid opening Vendor's name and return address

Central Arkansas Water Contact Information

	CAW Buyer:	Liz Tuck-Rowan, CPPO, CPPB	Direct Phone #:	(501) 377-1266
	Email Address:	liz.tuck-rowan@carkw.com	CAW's Main #:	(501) 377-1200
	Website:	www.carkw.com		

BID SIGNATURE PAGE

Vendor's Information

Type or Print the following information.

Company:			
Address:			
City:	State:	ZIP Code:	
Business Designation:	<input type="checkbox"/> Individual <input type="checkbox"/> Partnership	<input type="checkbox"/> Sole Proprietorship <input type="checkbox"/> Corporation	<input type="checkbox"/> Public Service Corp <input type="checkbox"/> Nonprofit
Minority Designation: <i>See Minority Business Policy</i>	<input type="checkbox"/> Not Applicable <input type="checkbox"/> African American <input type="checkbox"/> American Indian	<input type="checkbox"/> Hispanic American <input type="checkbox"/> Asian American	<input type="checkbox"/> Pacific Islander American <input type="checkbox"/> Service-Disabled Veteran AR Minority Certification #: _____ Service-Disabled Veteran Certification #: _____
Woman Owned Business:	<input type="checkbox"/> Yes, my company is a woman owned business <input type="checkbox"/> Not Applicable	Dun & Bradstreet #	DUNS #: _____

Vendor's Contact Information

Contact Person:		Title:	
Phone:		Alternate Phone:	
Email:			

Conflict of Interest Disclosure

	<p>Vendor should indicate below whether or not any known possible conflicts of interest exist with Central Arkansas Water. (See <i>Conflict of Interest Disclosure</i> in Section 1.)</p> <p>At the present time, and to the best of my knowledge, (vendor should select one of the following choices).</p> <p><input type="checkbox"/> No known possible conflicts of interest exist.</p> <p><input type="checkbox"/> Yes, a possible conflict of interest exists.</p> <p style="padding-left: 40px;">If yes, vendor must provide an explanation. _____</p> <p>_____</p>
--	--

Confirmation of Redacted Copy

	<p><input type="checkbox"/> YES, a redacted copy of submission documents is enclosed.</p> <p><input type="checkbox"/> NO, a redacted copy of submission documents is <u>not</u> enclosed. I understand a full copy of non-redacted submission documents will be released if requested.</p> <p><i>Note: If a redacted copy of the submission documents is not provided with vendor's response packet, and neither box is checked, a copy of the non-redacted documents, with the exception of financial data (other than pricing), shall be released in response to any request made under the Arkansas Freedom of Information Act (FOIA). See Bid Solicitation for additional information.</i></p>
--	--

Israel Boycott Restriction Confirmation

	<p>By checking and submitting a response to this <i>Bid Solicitation</i>, a Prospective Contractor agrees and certifies that they do not boycott Israel, and if selected will not boycott Israel during the aggregate term of the contract.</p> <p><input type="checkbox"/> Prospective Contractor does not and will not boycott Israel.</p>
--	--

Execution of Vendor's Bid Response

Vendor's signature below **shall** represent and warrant vendor's agreement to and compliance with all requirements, specifications, and terms and conditions within this solicitation. The undersigned official **must** be duly authorized to bind the vendor to a resultant contract. (See *Bid Signature Page* in Section 1 of this solicitation).

Authorized Signature: _____ Title: _____

Printed/Typed Name: _____ Date: _____

OFFICIAL BID PRICE SHEET

Attachment One

Excel spreadsheet

SECTION 1 – GENERAL INFORMATION

1.1 PURPOSE

This Invitation to Bid (ITB) has been issued by Central Arkansas Water (CAW) to obtain pricing and a contract for the purchase One (1) Service Body and One (1) Undercarriage, PTO Driven Air Compressor. Chassis vendor will be responsible for coordinating service body installation and payment pass thru to service body vendor.

1.2 BACKGROUND INFORMATION

Central Arkansas Water (CAW or the Utility) is the largest water supplier in the state of Arkansas. The Utility plays an integral role in the quality of life for residents and the economic health of the communities it serves. As a regional water supplier serving a population of approximately 500,000, CAW contributes to the public health and wellbeing of one in every six Arkansans. In addition, CAW supplies the water needed by industries that compete in regional, national, and international markets. The Utility serves approximately 158,000 metered connections through retail and wholesale service to customers in Pulaski, Saline, Grant, Perry, Lonoke, White, and Faulkner counties.

1.3 TYPE OF CONTRACT/CONTRACT PERIOD

This contract **shall** be a firm fixed price contract. In case of default by the bidder, CAW may procure the commodities or services from other sources and may deduct from any monies due, or that may thereafter become due to the bidder, the difference between the price named in the contract or purchase order and actual thereof to CAW. The term of this Agreement shall commence after contract award date and delivery within one hundred twenty (120) days.

1.4 ISSUING OFFICE

The CAW Purchasing Section, as the issuing office, is the sole point of contact throughout this procurement process. Vendor's questions regarding this solicitation should be made through the CAW buyer listed on page one (1) of this solicitation.

1.5 BID OPENING LOCATION

Sealed bid responses submitted by the bid opening time and date **shall** be opened at the following location:

Central Arkansas Water
Purchasing Section
221 East Capitol Avenue
Little Rock, AR 72202

1.6 CONE OF SILENCE

All communication(s) pertaining to this solicitation **shall** be directed to the CAW buyer listed on page one (1) of this solicitation, or his or her designee. CAW has imposed an absolute prohibition against any communication or contact ("Cone of Silence") with any other CAW personnel, CAW consultant, or Central Arkansas Water Commission (CAWC) member regarding this solicitation process.

The prohibition begins with the publication of this solicitation document, remains in place through the CAW solicitation and award process, and ends only after CAW has executed a contract with the successful vendor. The prohibition is suspended only when the CAW Buyer, or his or her designee, initiates or consents to a meeting or communications for the purpose of clarifying a solicitation or another solicitation-related action.

A violation of this policy may result in the disqualification of an offending vendor's response.

1.7 DEFINITION OF REQUIREMENT

- A. The words "**must**" and "**shall**" signify a requirement of this solicitation and that vendor's agreement to and compliance with that item is mandatory.
- B. Exceptions taken to any requirement in this solicitation, whether submitted in the vendor's bid response or in subsequent correspondence, may cause the vendor's bid response to be disqualified.
- C. Vendor may request exceptions to non-mandatory items. Vendor should clearly explain the requested exception and should reference the specific solicitation item number to which the exception applies.

1.8 DEFINITION OF TERMS

- A. CAW has made every effort to use industry-accepted terminology in this solicitation.

- B. "Central Arkansas Water", "CAW", and the "utility" are used synonymously in this document.
- C. "Central Arkansas Water Commission", "CAWC" and the "commission" are used synonymously in this document.
- D. The words "bidder", "vendor" or "Contractor" are used synonymously in this document.
- E. The terms "Invitation to Bid", "ITB", and "Solicitation" are used synonymously in this document.
- F. The following acronyms are defined:

ANSI	American National Standards Institute
AMS	Asset Management System

1.9 BID RESPONSE DOCUMENTS

- A. Original Bid Response (Bid may be submitted electronically to the following email on or before the established bid opening date and time: procurement@carkw.com) Adhere to 2-4 requirements below.
 - 1. Vendor's original bid response **must be delivered to CAW in a sealed package** on or before the established bid opening date and time.
 - 2. Original bid response **must** include the following:
 - a. Original signed *Bid Signature Page*. (See *Bid Signature Page* below.) (Flash drive not required)
 - b. Completed *Official Bid Price Sheet*. (See *Pricing*.)
 - c. Other documents and/or information as may be expressly required in this solicitation.
 - 3. Original bid response should include a list of subcontractors, if applicable.
 - 4. DO NOT include any other documents or ancillary information, such as a cover letter or promotional/marketing information.
- B. Electronic Copy and Redacted Copy of the Bid Response (Bid may be submitted electronically to the following email: procurement@carkw.com) Flash drive not required with this bid.

In addition to the original bid response, vendor should submit the following items:

- 1. One (1) electronic copy of the original bid response, preferably on a flash drive. The electronic copies **must** be identical to the original hard copy. In case of a discrepancy, the original hard copy **shall** govern.
- 2. One (1) redacted copy (marked "REDACTED") of the original bid response, preferably on a flash drive. (See *Proprietary Information*.)

1.10 ADDITIONAL SOURCE OF BID INFORMATION:

AR Bid: The official bid posting can also be found on the AR Bid website at <https://arkansas.ionwave.net> The solicitation document can be downloaded from the attachments tab of this bid posting. Note: it is the vendor's responsibility to properly register and utilize the AR Bid website.

1.11 AWARD PROCESS

- A. Award Criteria
 - 1. Award **shall** be made to the lowest responsive, responsible bidder as recorded on the *Official Bid Price Sheet*.
 - 2. CAW **shall** have the right to negotiate with any vendor who submits a bid determined to be reasonably susceptible of being selected for an award.
- B. Central Arkansas Water Commission Approval

Any resultant contract of this solicitation **shall** be subject to CAW approval processes which may include CAWC review and approval.

C. Issuance of a Contract

1. A CAW Purchasing Official, with approval by the CAWC, **shall** be responsible for award and administration of any resulting contract.
2. A contract **shall not** be effective prior to award being made by a CAW Purchasing Official.

1.12 BID SIGNATURE PAGE

- A. An official authorized to bind the vendor(s) to a resultant contract **must** sign the *Bid Signature Page* included in the solicitation.
- B. Vendor's signature on the *Bid Signature Page* **shall** represent and warrant vendor's agreement that either of the following may cause the vendor's bid to be disqualified:
 1. Additional terms or conditions submitted intentionally or inadvertently.
 2. Any exception that conflicts with a requirement of this solicitation.
- C. Vendor's signature on the *Bid Signature Page* **shall** represent and warrant the following:
 1. Vendor has completely reviewed this solicitation and any addenda.
 2. Vendor's agreement to and compliance with all requirements, specifications, and terms and conditions within this solicitation. (See *Definition of Requirement*.)
 3. Vendor's agreement to and compliance with all laws relating to State and Federal Equal Opportunity and Non-Discrimination requirements and conditions of employment, in addition to all federal, State, and local laws.
 4. Vendor has provided information in response to this solicitation that is both accurate and true.

1.13 PRICING

- A. All charges **must** be included on the *Official Bid Price Sheet* and **must** include all associated cost for the items and/or services being bid. CAW **shall not** be obligated to pay any costs not identified on the *Official Bid Price Sheet*. Any cost not identified by the successful vendor but subsequently incurred to achieve requirements **shall** be borne by the vendor.
- B. The *Official Bid Price Sheet* is provided as a separate excel spreadsheet posted on the CAW website with this *Bid Solicitation* document.
- C. Bid pricing **must** be valid for 90 days following bid opening.
- D. Failure to complete and submit the *Official Bid Price Sheet* **shall** result in disqualification.
- E. All bid pricing **must** be in United States dollars and cents.
- F. The *Official Bid Price Sheet* may be reproduced as needed.

1.14 PRICE CHANGE CLAUSE

- A. In the event of a general price decrease, CAW **shall** be guaranteed full benefit of the price reduction for all undelivered orders on the effective date of the decrease and thereafter.

1.15 REQUIREMENT OF ADDENDUM

- A. This solicitation **shall** be modified only by an addendum written and authorized by CAW.
- B. The vendor **shall** be responsible for checking the Purchasing Section of the CAW website www.carkw.com for any and all addenda up to the established bid opening date and time.

1.16 **NONCOLLUSION**

Vendor **shall** represent and warrant that in connection to a response to this solicitation:

- A. The vendor has not been a party to any collusion among vendor(s) in the restraint of freedom of competition by agreement to bid at a fixed price or to refrain from bidding.
- B. The vendor has not been a party to any collusion with any official or employee of CAW as to quantity, quality, or price in the prospective contract, or any other terms of said prospective contract.
- C. The vendor has not been a party in any discussion between bidders and any official of CAW concerning exchange of money or other things of value for special consideration in the letting of a contract.

1.17 **CONFLICT OF INTEREST DISCLOSURE**

- A. Vendor should complete the *Conflict of Interest Disclosure* section on the *Bid Signature Page* of this solicitation.
- B. Vendor **must** disclose all known possible conflicts of interest, which exist at the time of vendor's bid submission. Conflicts of interest include, but are not limited to the following:
 1. Relationships between vendor's employees, principals, officers, and agents and the employees of CAW.
 2. Relationships between vendor's employees, principals, officers, and agents and the CAWC.
 3. Those resulting from material adverse matters, as distinguished from the conduct of business as usual.
- C. Vendor's failure to disclose such a relationship may result in one of the following:
 1. CAW's rejection of vendor's bid response.
 2. CAW's cancellation of any resultant contract.

1.18 **ISRAEL BOYCOTT NOTICE**

- A. Pursuant to Arkansas Code Annotated § 25-1-503, a public entity **shall not** enter into a contract valued at \$1,000 or greater with a company unless the contract includes a written certification that the person or company is not currently engaged in and agrees for the duration of the contract not to engage in, a boycott of Israel.
- B. Vendor's signature on the Bid Signature Page **shall** represent and warrant they do not boycott Israel and will not boycott Israel during the remaining aggregate term of the contract.

1.19 **PRIME CONTRACTOR RESPONSIBILITY**

- A. A joint bid response submitted by two or more vendors is acceptable. However, a single vendor **must** be identified as the prime contractor.
- B. The prime contractor **shall** be held responsible for the contract and **shall** be the sole point of contact.
- C. The prime contractor **shall** give CAW immediate notice, in writing, by certified mail of any action which, in the opinion of the contractor, may result in litigation related in any way to this contract or CAW.

1.20 **SUBCONTRACTORS**

If any part of the work must be subcontracted, vendor should include a list of subcontractors, including firm name and address, contact person, complete description of work to be subcontracted with their bid response. This information **must** be provided prior to any contract award.

1.21 **PROPRIETARY INFORMATION**

- A. Response documents pertaining to this solicitation will become the property of CAW and **shall** be subject to the Arkansas Freedom of Information Act (FOIA).
- B. One (1) complete copy of the original bid response from which any proprietary and/or confidential information has been redacted should be submitted on a flash drive in the vendor's response.
- C. Except for the redacted information, the redacted copy **must** be identical to the original hard copy, reflecting the same pagination as the original and showing the space from which information was redacted.
- D. The vendor **shall** be responsible for identifying all proprietary information and for ensuring the electronic copy is protected against restoration of redacted data.

- E. The redacted copy **shall** be open to public inspection under the Freedom of Information Act (FOIA) without further notice to the vendor.
- F. If a redacted copy of the submission documents is not provided with vendor's bid response, a copy of the non-redacted documents, with the exception of financial data (other than pricing), **shall** be released in response to any request made under the Arkansas Freedom of Information Act (FOIA).
- G. If CAW deems redacted information to be subject to FOIA, the vendor will be contacted prior to release of the documents.

1.22 CAUTION TO VENDORS

- A. Vendor **must not** alter any language in any solicitation document provided by CAW.
- B. Vendor represents and warrants that the product and/or service offered **shall** meet or exceed specifications identified in this solicitation.
- C. All official documents and correspondence related to this solicitation **shall** be included as part of the resultant contract.
- D. Bid responses **must** be submitted only in the English language.
- E. CAW **shall** have the right to award or not award a contract, if it is in the best interest of CAW to do so.
- F. CAW **shall** have the right to accept or reject all or any part of a bid response, if it is in the best interest of CAW to do so.
- G. Vendor **must** provide clarification of any information in their bid response documents as requested by CAW.
- H. Vendors may submit multiple bid responses. Each bid response should be submitted in a separately sealed envelope.
- I. Vendor may withdraw their bid response. To withdraw a bid response, vendor **must** provide a written request to the CAW Purchasing Section.
- J. Reference to handbooks or other technical materials as part of a bid response **must not** constitute the entire bid and vendor **must** identify the specific page and paragraph being referenced.

1.23 PAST PERFORMANCE

A vendor's past performance with CAW may be used to determine if the vendor is "responsible". Bids responses submitted by vendors determined to be non-responsible **shall** be disqualified.

1.24 PUBLICITY

Vendor **shall not** issue a news release or article pertaining to this solicitation or any portion of the project, in any medium, at any time during the pendency of the solicitation or fulfillment of the terms of this contract without CAW's prior written approval. Vendor's failure to comply with this requirement may be cause for CAW's rejection of Vendor's response or CAW's cancellation of this contract.

1.25 RESERVATION

This solicitation **shall not** commit CAW to issue an award or contract. CAW **shall not** pay costs incurred in the preparation of a bid response.

1.25 MULTI-AGENCY PROCUREMENT

CAW, as the issuing office for this solicitation, **shall** also be the lead agency for this contract. Other governmental entities **shall** be allowed to utilize this contract for purchases that fall under its scope throughout the life of the contract. This clause in no way commits other governmental entities to purchase from the awarded vendor, nor does it guarantee any additional orders will result. This clause allows other governmental entities, at their discretion, to make use of CAW's competitive process and purchase directly from the awarded vendor, provided said process satisfies their own procurement laws and guidelines. All purchases made by other governmental entities **shall** be understood to be transactions between the awarded vendor and that entity. CAW **shall not** assume any authority, liability, or obligation, on behalf of any other governmental entity that may use any contract resulting from this solicitation. All purchases and payment transactions **shall** be made directly between the vendor and the requesting entity.

SECTION 2 – SPECIFICATIONS

2.1 SCOPE OF WORK

- A. Vendor **shall** be responsible for providing the required one (1) Crew Truck Service Body per the stated specifications. **See Attachment One.**
- B. Vendor **must** meet or exceed all requirements and specifications as set forth in this solicitation. CAW **shall** have the right to amend specifications and requirements, to add or remove specifications, to add or remove service locations, and to add or remove any services offered by the vendor under the scope of this contract, based on revisions in federal, State, and/or local regulations, or as determined to be in the best interest of CAW. Vendor and CAW **shall** come to a written agreement regarding negotiated cost for such changes.
- C. CAW **shall** have the right to assess damages which **shall** be deducted from the payment for goods. At the sole discretion of CAW, damages may be assessed based on vendor's failure to meet the requirements of this contract.

2.2 ORDERING PROCEDURE

Orders placed against this contract **shall** be in the form of a CAW issued purchase order.

2.3 DELIVERY

- A. Delivery **shall** be FOB destination to the delivery addresses stated in the bid specifications. All freight, shipping and handling charges **must** be included in bid price. Loss or damage that occurs during shipping prior to the order being received by CAW **shall** be the vendor's responsibility.
- B. Vendor **shall** give CAW immediate notice of any anticipated delays or plant shutdowns that will affect the delivery requirement.

2.4 INTELLECTUAL PROPERTY

- A. Upon completion of the contract, all property rights, intellectual or otherwise, and technology transfer **shall** be passed to CAW. This includes all rights in relation to any patents, trademarks, etc. that may be associated. Upon transfer, any and all code, data and the like, both intellectual and tangible, pertaining to any responsibilities including but not limited to reports, records, data, graphic art design, and products under the contract **shall** be delivered to CAW without cost within a time frame of 30 calendar days upon completion of the contract. This job is considered a "work for hire" for CAW. Contractor **shall hold no** ownership or intellectual property claim on any deliverable produced for CAW.
- B. Each deliverable/product **shall** become the exclusive property of Central Arkansas Water. Vendor **shall not** utilize any portion of this project, including deliverables and data, without prior written consent of the Chief Executive Officer of Central Arkansas Water.

2.5 WARRANTY

- A. Vendor **must** provide standard manufacturers/product warranty.

2.6 ACCEPTANCE

Inspection and acceptance/rejection of product(s) will be made within 14-days of receipt. CAW **shall** have the option to return any product(s) within the 14-day timeframe for any reason. Bid **must** include a total satisfaction return policy for all products and **shall not** impose any liability on CAW for such returns.

SECTION 3 – GENERAL CONTRACTUAL REQUIREMENTS

3.1 PAYMENT AND INVOICE PROVISIONS

A. All invoices **must** be forwarded to:

Central Arkansas Water
ATTN: Accounts Payable
P.O. Box 1789
Little Rock, AR 72203

Or emailed to: accounting_ap@carkw.com

- B. Payment will be made in accordance with applicable CAW accounting procedures upon acceptance of goods and/or services by CAW.
- C. CAW **shall not** be invoiced in advance of delivery and acceptance of any goods or services.
- D. Payment will be made only after the vendor has successfully satisfied CAW as to the reliability and effectiveness of the goods and/or services purchased as a whole.
- E. The vendor should invoice CAW by an itemized list of charges. CAW's bid number should be referenced on each invoice.
- F. Other sections of this solicitation may contain additional requirements for invoicing.

3.2 GOVERNING LAW

- A. The laws of the State of Arkansas **shall** govern this contract as to interpretation and performance.
- B. Any and all legal action necessary to enforce any resulting contract **shall** be brought in Pulaski County, Arkansas.
- C. CAW **shall not** agree to any provision of a contract which violates the federal, State, or local laws or the constitution of the State of Arkansas.

3.3 CONDITIONS OF CONTRACT

The vendor **shall** at all times observe and comply with federal and State of Arkansas laws, local laws, ordinances, orders, and CAW polices and regulations existing at the time of, or enacted subsequent to the execution of a resulting contract which in any manner affect the completion of the work.

3.4 INDEMNITY

Vendor **shall** indemnify and save harmless CAW and its agents, servants, and employees from, and against, any and all suits, actions, legal proceedings, claims, demands, damages, costs, expenses, or losses of any nature whatsoever, civil or criminal, incurred by any of them including attorney's fees arising out of a willful or negligent act, or omission, including, but not limited to actions arising under any local, state or federal environmental laws or regulations, or omissions of Vendor, its officers, agents, servants, and employees; provided, however, that Vendor **shall not** be liable for any suits, actions, legal proceedings, claims, demands, damages, costs, expenses, and attorney's fees arising out of the award of any resulting contract due to a willful or negligent act, or omission, of CAW, its agents, servants, and employees.

3.5 STATEMENT OF LIABILITY

CAW will demonstrate reasonable care but **shall not** be liable in the event of loss, destruction, or theft of vendor-owned items to be delivered or to be used in the installation of deliverables. The vendor **shall** be required to retain total liability until the deliverables have been accepted by the authorized CAW official. CAW **shall not** be responsible for or accept liability for any vendor-owned items.

3.6 NON-DISCRIMINATION

As a condition for doing business with Central Arkansas Water, the awarded contractor **shall not** discriminate on the basis of race, color, creed, religion, sex, national origin, age, disability, marital status, sexual orientation, gender identity, genetic information, political opinions or affiliation, military status, or other status protected by applicable law and **shall** require such compliance in agreements with subcontractors and sub-subcontractors.

3.7 DELEGATION AND/OR ASSIGNMENT

Vendor **shall not** assign the contract or any portion thereof or delegate any of vendor's right or duties thereunder without prior written approval of CAW. This written approval **shall not** be considered as making CAW a party to such subcontract or subjecting CAW to liability of any kind to any subcontractor. No subcontract **shall** under any circumstances relieve vendor of liability and obligation under any resulting contract, and all transactions **shall** be made through vendor. Subcontractors **shall** be recognized and dealt with only as workers and representatives of vendor and as such **shall** be subject to the same requirements of character and competence as required of vendor's employees. Any purported assignment made in violation of this provision **shall** be void and of no force and effect and **shall** constitute a material breach of any resulting contract.

3.8 RECORD RETENTION

- A. The vendor **shall** maintain all pertinent financial and accounting records and evidence pertaining to the contract in accordance with generally accepted principles of accounting and other specified CAW policies. Upon request, access **shall** be granted to CAW, State or Federal Government entities or any of their duly authorized representatives.
- B. Financial and accounting records **shall** be made available, upon request, to the CAW's designee(s) at any time during the contract period and any extension thereof, and for five (5) years from expiration date and final payment on the contract or extension thereof.
- C. Other sections of this solicitation may contain additional Requirements regarding record retention.

3.9 CONFIDENTIALITY

- A. The vendor, vendor's subsidiaries, and vendor's employees **shall** be bound to confidentiality of any information of which they may become aware during the course of providing services under a resulting contract.
- B. The vendor, vendor's subsidiaries, and vendor's employees **shall** be bound to all federal, State, and local laws and to all requirements set forth in this solicitation and/or resulting contract concerning the confidentiality and secure handling of information of which they may become aware during the course of providing services under a resulting contract.
- C. Consistent and/or uncorrected breaches of confidentiality may constitute grounds for cancellation of contract, and CAW **shall** have the right to cancel the contract on these grounds.

3.10 CONTRACT INTERPRETATION

Should CAW and vendor interpret specifications differently, either party may request clarification. However, if an agreement cannot be reached, the determination of CAW **shall** be final and controlling.

3.11 CANCELLATION FOR CONVENIENCE

- A. CAW **shall** have the right to cancel a contract, in whole or in part, in the event CAW no longer needs the service or commodity specified in the contract due to program changes, changes in laws, rules, or regulations, relocation of offices, lack of appropriated funding, or if it is determined to be in CAW's best interest to do so. CAW **shall** give the vendor written notice of cancellation, specifying the terms and the effective date of contract termination. The effective date of termination **shall** be 30 days from the date of notification, unless specified in the notification.
- B. In the event CAW cancels a contract for one of the above reasons, CAW **shall** pay only those sums due for services and/or goods received and accepted up to the termination date as stated in the notification.
- C. The vendor may terminate any resulting contract by providing written notice of cancellation to CAW. Vendor **must** confirm with CAW that notice of cancellation has been received. Notice of cancellation **must** be provided to CAW a minimum of 90 days prior to termination of contract.

3.12 TERMINATION FOR CAUSE

- A. *Cause.* In the event of Termination for Cause, the thirty (30) days advance notice is waived and Contractor: At any time 1) Contractor fails to conform to the requirements of the Contract; 2) Contractor seeks relief under any law for benefit of insolvents or is adjudicated bankrupt; 3) any legal proceedings are commenced against Contractor which may interfere with the performance of the Contract or 4) Contractor has failed to supply an adequate working force or has failed in any other respect to prosecute the work with the diligence and force specified and intended in and by the terms of the Contract, which default is not fully corrected or remedied to the

reasonable satisfaction of CAW within ten (10) days following the date a written notice thereof by CAW, then CAW shall have the right and power, at its option and without prejudice to any other rights or remedies it may have, to immediately terminate the Contract. Any cost or expense incurred by CAW arising out of Contractor's breach or default hereunder, and for CAW's enforcement of these rights, shall be the obligation of Contractor and may, at CAW's discretion, be deducted from any amounts that may then be owing to Contractor under the Contract, without any release or waiver of any other rights or remedies in law or equity to which CAW may be entitled.

- B. *Contractor's Duties.* Notwithstanding termination of the Contract and subject to any direction from CAW, Contractor shall take timely, reasonable, and necessary action to protect and preserve property in the possession of Contractor in which CAW has an interest.
- C. *Compensation.* Payment for completed services delivered and accepted by CAW shall be at the contract price.
- D. *Additional Rights and Remedies.* The rights and remedies provided in this clause are in addition to any other rights and remedies provided by law.

3.13 MODIFICATION

The Agreement shall not be modified, except by written amendment, executed by all parties. Oral change orders are not permitted. No change in the Agreement shall be made unless CAW gives prior written approval. Any specification changes not properly ordered by written modification to the Agreement executed by CAW shall be void at the sole option of CAW and CONTRACTOR shall be liable for all costs or expenses arising there from and/or for satisfactorily correcting or replacing same.

3.14 ATTORNEY'S FEES AND EXPENSES

Subject to other terms and conditions of this Contract, in the event Contractor defaults in any obligations under this Contract, Contractor shall pay to CAW all costs and expenses (including, without limitation, investigative fees, court costs, and attorney's fees) incurred by CAW in enforcing this Contract or otherwise reasonably related thereto. Contractor agrees that under no circumstances shall CAW be obligated to pay any attorney's fees or costs of legal action to Contractor.

3.15 AUTHORITY TO CONTRACT

Contractor warrants: (a) that it is a validly organized business with valid authority to enter into this Contract; (b) that it is qualified to do business and in good standing in the State of Arkansas; (c) that entry into and performance under this Contract is not restricted or prohibited by any loan, security, financing, contractual, or other agreement of any kind; and, (d) notwithstanding any other provision of this Contract to the contrary, that there are no existing legal proceedings or prospective legal proceedings, either voluntary or otherwise, which may adversely affect its ability to perform its obligations under this Contract.

3.16 DEBARMENT AND SUSPENSION

Contractor certifies to the best of its knowledge and belief, that it:

is not presently debarred, suspended, proposed for debarment, declared ineligible, or voluntarily excluded from covered transaction by any federal department or any political subdivision of the State of Arkansas;

has not, within a three (3) year period preceding this proposal, been convicted of or had a civil judgment rendered against it for commission of fraud or a criminal offense in connection with obtaining, attempting to obtain, or performing a public (federal, state, or local) transaction or contract under a public transaction;

has not, within a three (3) year period preceding this proposal, been convicted of or had a civil judgment rendered against it for a violation of federal or state antitrust statutes or commission of embezzlement, theft, forgery, bribery, falsification or destruction of records, making false statements, or receiving stolen property;

is not presently indicted for or otherwise criminally or civilly charged by a governmental entity (federal, state or local) with commission of any of these offenses enumerated in paragraphs two (2) and three (3) of this certification; and,

has not, within a three (3) year period preceding this proposal, had one or more public transactions (federal, state, or local) terminated for cause or default.

3.17 FORCE MAJEURE

Each party shall be excused from performance for any period and to the extent that it is prevented from performing any obligation or service, in whole or in part, as a result of causes beyond the reasonable control and without the fault or negligence of such party. Such acts shall include without limitation acts of God, strikes, lockouts, riots, acts of war, epidemics, governmental regulations superimposed after the fact, fire, earthquakes, floods, or other natural disasters (“force majeure events”). When such a cause arises, Contractor shall notify CAW immediately in writing of the cause of its inability to perform, how it affects its performance, and the anticipated duration of the inability to perform. Delays in delivery or in meeting completion dates due to force majeure events shall automatically extend such dates for a period equal to the duration of the delay caused by such events, unless CAW determines it to be in its best interest to terminate the Contract.

3.18 INDEPENDENT AGENT STATUS

Contractor shall, at all times, be regarded as and shall be legally considered an independent contractor and shall at no time act as an agent for CAW. Nothing contained herein shall be deemed or construed by CAW, Contractor, or any third party as creating the relationship of principal and agent, master and servant, partners, joint ventures, employer and employee, or any similar such relationship between CAW and Contractor. Neither the method of computation of fees or other charges, nor any other provision contained herein, nor any acts of CAW or Contractor hereunder creates, or shall be deemed to create a relationship other than the independent relationship CAW and Contractor. Contractor’s personnel shall not be deemed in any way, directly or indirectly, expressly or by implication, to be employees of CAW. Neither Contractor nor its employees shall, under any circumstances, be considered servants, agents, or employees of CAW and CAW shall be at no time legally responsible for any negligence or other wrongdoing by Contractor, its servants, agents, or employees. CAW shall not withhold from the contract payments to Contractor any federal or state unemployment taxes, federal or state income taxes, Social Security tax, or any other amounts for benefits to Contractor. Further, CAW shall not provide to Contractor any insurance coverage or other benefits, including Worker’s Compensation, normally provided by CAW for its employees.

3.19 NO LIMITATION OF LIABILITY

Nothing in this Contract shall be interpreted as excluding or limiting any tort liability of Contractor for harm caused by the intentional or reckless conduct of Contractor or for damages incurred through the negligent performance of duties by Contractor.

3.21 OWNERSHIP OF DOCUMENTS AND WORK PAPERS

CAW shall own all documents, files, reports, work papers and working documentation, electronic or otherwise, created in connection with the provision of services under this Contract, except for Contractor’s internal administrative and quality assurance files and internal correspondence.

3.22 APPLICABLE LAW

This contract shall be governed by and construed in accordance with the laws of the State of Arkansas, excluding its conflicts of law’s provisions, and any litigation with respect thereto shall be brought in the courts of the State of Arkansas located in Pulaski County, Arkansas. Contractor hereby irrevocably consents to the personal jurisdiction of Circuit Court of Pulaski County, Arkansas upon and over Contractor.

3.22 APPLICABILITY OF FREEDOM OF INFORMATION ACT

Contractor acknowledges that CAW is subject to the requirements of the Arkansas Freedom of Information Act (the “FOIA”) and to the extent Contractor performs work for CAW, Contractor may also be subject to requirements of the FOIA. Therefore, each party shall assist and cooperate with the other (at their own expense) to enable the other party to comply with any applicable information disclosure obligations under the FOIA. Whenever a party receives a request for information under the FOIA in relation to the Contract or information which it is holding on behalf of the other party, it shall (and shall procure that its sub-contractors shall):

- i. transfer the request for information to the other party as soon as practicable after receipt and in any event within one (1) working day of receiving the request for information;
- ii. provide the other party with a copy of all information in its possession or power in the form that the other party requires within two (2) working days (or such other period as the other party may specify) of the other party requesting that information; and
- iii. provide all necessary assistance as reasonably requested by the other party to enable the other party to respond to the request for information within the relevant time for compliance as set out in the FOIA.

Each party shall be responsible for determining at its absolute discretion whether:

- i. the information is exempt from disclosure under the FOIA; or
- ii. the information is to be disclosed in response to a request for information

3.23 HOLD HARMLESS CLAUSE

The Contractor shall, indemnify, defend, and hold harmless CAW from loss from all suits, actions, or claims of any kind brought as a consequence of any negligent act of omission by the Contractor. The Contractor agrees that this clause shall include claims involving infringement of patent or copyright. For purposes of this paragraph, "CAW" and "Contractor" includes their employees, officials, agents, and representatives. "Contractor" also includes subcontractors and suppliers to the Contractor. The word "defend" means to provide legal counsel for CAW or to reimburse CAW for its attorneys' fees and costs related to the claim. This section shall survive the Contract. CAW is prohibited from indemnifying Contractor and/or any other third parties.

3.24 NON-DISCRIMINATION POLICY

Central Arkansas Water shall not discriminate against or in the selection of vendors because of the race, color, creed, religion, sex, national origin, age, disability, veteran's status, marital status, sexual orientation, gender identity, genetic information, political opinions or affiliation, or any other status protected by law of the vendor's owners or personnel.

By submission of a response, you agree that you shall not discriminate in your employment practices or your provision of goods or services to others on the basis of race, color, creed, religion, sex, national origin, age, disability, veteran's status, marital status, sexual orientation, gender identity, genetic information, political opinions or affiliation.

3.25 COMPLIANCE WITH LAWS

Contractor shall comply with, and all activities under this Contract shall be subject to, all applicable federal, state, and local laws and regulations, as now existing and may be amended or modified.

3.26 INSURANCE

- A. Contractor shall be responsible for its work and every part thereof, and for all materials, tools, equipment, appliances, and property of any and all description used in connection therewith. Contractor assumes all risk of direct and indirect damage or injury to the property or persons used or employed on or in connection with the work contracted for, and of all damage or injury to any person or property wherever located, resulting from any action, omission, commission or operation under the Contract.
- B. Contractor and all subcontractors shall, during the continuance of all work under the Contract provide the following:
 1. Workers' Compensation and Employer's Liability to protect Contractor from any liability or damages for any injuries (including death and disability) to any and all of its employees, including any and all liability or damage which may arise by virtue of any statute or law in force within the State of Arkansas.
 2. Comprehensive General Liability insurance to protect Contractor, and the interest of CAW, its officers, commissioners, employees, and agents against any and all injuries to third parties, including bodily injury and personal injury wherever located, resulting from any action or operation under the Contract or in connection with the contracted work. The General Liability insurance shall also include the Broad Form Property Damage endorsement, in addition to coverage for explosion, collapse, and underground hazards, where required.
 3. Automobile Liability insurance, covering all owned, borrowed, leased, or rented vehicles operated by Contractor.
- C. Contractor agrees to provide the above referenced policies with the following limits. Liability insurance limits may be arranged by General Liability and Automobile policies for the full limits required, or by a combination of underlying policies for lesser limits with the remaining limits provided by an Excess or Umbrella Liability policy.

1. Workers' Compensation:

Coverage A:	Statutory
Coverage B:	\$500,000/\$500,000/\$500,000

2. General Liability:

Per Occurrence:	\$1,000,000
Personal/Advertising Injury:	\$1,000,000
General Aggregate:	\$2,000,000
Products/Completed Operations:	\$2,000,000
Aggregate	
Fire Damage Legal Liability	\$100,000

GL Coverage, excluding Products and Completed Operations, should be on a Per Project Basis

3. Automobile Liability:

Combined Single Limit:	\$1,000,000
------------------------	-------------

D. The following provisions shall be agreed to by Contractor:

1. Contractor will provide an original signed Certificate of Insurance and such endorsements as prescribed herein.
 - a. Contractor will provide on request certified copies of all insurance coverage Certificates of Insurance related to the Contract within ten (10) business days of request by CAW. These certified copies will be sent to CAW from Contractor's insurance agent or representative.
 - b. Any Certificate of Insurance provided shall indicate the Contract name and number.

2. No change, cancellation, or non-renewal shall be made in any insurance coverage without a forty-five (45) day written notice to CAW. Contractor shall furnish a new Certificate of Insurance prior to any change or cancellation date. The failure of Contractor to deliver a new and valid Certificate of Insurance will result in suspension of all payments until the new Certificate of Insurance is furnished.

3. Liability Insurance "Claims Made" basis: If the liability insurance purchased by Contractor has been issued on a "claims made" basis, Contractor must comply with the following additional conditions. The limits of liability and the extensions to be included as described previously in these provisions, remain the same. Contractor must also agree to provide certificates of insurance evidencing the above coverage for a period of two (2) years after final payment for Contractor for General Liability policies. This certificate shall evidence a "retroactive date" no later than the beginning endorsement by means of a certificate of insurance or a copy of the endorsement itself.

4. Contractor must disclose the amount of deductible/self-insured retention applicable to the General Liability and Automobile Liability. CAW reserves the right to request additional information to determine if Contractor has the financial capacity to meet its obligations under a deductible/self-insured plan. If this provision is utilized, Contractor will be permitted to provide evidence of its ability to fund the deductible/self-insured retention.

5. Contractor agrees to provide insurance issued by companies within the State of Arkansas, with the Best's Key Rating of at least A:VII.

6. CAW, its officers and employees shall be endorsed to Contractor's Automobile and General Liability policies as an "additional insured" with the provision that this coverage "is primary to all other coverage CAW may possess." (Use "loss payee" where there is an insurable interest). A Certificate of Insurance evidencing the additional insured status must be presented to CAW along with a copy of the Endorsement.

7. Contractor will provide a waiver of subrogation endorsement in favor of CAW on their Commercial Auto, General Liability and Workers' Compensation Policies.

8. Compliance by Contractor with the foregoing requirements as to carry insurance shall not relieve Contractor of their liability's provisions of the Contract.
- E. Precaution shall be exercised at all times for the protection of persons (including employees) and property.
- F. Contractor is to comply with the Occupational Safety and Health Act of 1970, Public Law 91-956, as it may apply to this Contract.
- G. If an "ACORD" Insurance Certificate form is used by Contractor's insurance agent, as it relates to Cancellation "SHOULD ANY OF THE ABOVE-DESCRIBED POLICIES BE CANCELLED BEFORE THE EXPIRATION DATE THEREOF, NOTICE WILL BE DELIVERED IN ACCORDANCE WITH THE POLICY PROVISIONS."; the agent shall state the cancellation provisions either on company letterhead or copy of that portion of the policy.
- H. Contractor agrees to waive all rights of subrogation against CAW, its officers, employees, and agents.

3.27 SUBCONTRACTORS

Subcontractors cannot be used on this project.

3.28 SAFETY

All Contractors and subcontractors performing services for CAW are required to and shall comply with all Occupational Safety and Health Administration (OSHA), State and County Safety and Occupational Health Standards and any other applicable rules and regulations. Also, all Contractors and subcontractors shall be held responsible for the safety of their employees and any unsafe acts or conditions that may cause injury or damage to any persons or property within and around the work site under this Contract.

SECTION 4 – STANDARD TERMS AND CONDITIONS

- 1. GENERAL:** Any special terms and conditions included in the *Invitation to Bid* override these standard terms and conditions. The standard terms and conditions and any special terms and conditions become part of any contract entered into if any or all parts of the bid are accepted by Central Arkansas Water.

Any ambiguity in any bid as the result of omission, error, lack of clarity or non-compliance by the bidder with specifications, instructions, and all conditions of bidding shall be construed in the light most favorable to CAW.

Quality, time and probability of performance may be factors in making award.

- 2. ACCEPTANCE AND REJECTION:** The CAWC and/or their designees reserves the right to reject any and all bids, waive any and all informalities, award items, all or none, or by line item(s), and to make an award to the best bidder pursuant to law.
- 3. BID SUBMISSION:** Bids must be submitted to CAW on this form, with all other information required within the bid invitation, on or before the date and time specified for bid opening. If this form is not used, the bid may be rejected. The bid must be typed or printed in ink. The signature must be in ink. Unsigned bids will be disqualified. The person signing the bid should show title or authority to bind his firm in a contract. Each bid should be placed in a separate envelope completely and properly identified. Late bids will not be considered under any circumstances.

The bid number should be stated on the face of the Sealed Bid Envelope. If it is not, the envelope will have to be opened to identify.

- 4. PRICES:** Bid unit price F.O.B. destination at designated CAW facility in Little Rock/North Little Rock/Roland. Charges may not be added after the bid is opened. In case of errors in extension, unit prices shall govern. Prices shall be firm and not subject to escalation unless otherwise specified in the bid invitation. Unless otherwise specified, the bid must be firm for acceptance for sixty days from the bid opening date. "Discount from list" bids shall not be acceptable unless requested in the bid invitation.
- 5. QUANTITIES:** Quantities stated in **term contracts** are estimates only and shall not be guaranteed. Bid unit price on the estimated quantity and unit of measure specified. CAW may order more or less than the estimated quantity on term contracts. Quantities stated on **firm contracts** are actual requirements of CAW.
- 6. SPECIFICATIONS:** Specifications furnished with this invitation are intended to establish a desired quality of performance level, or other minimum dimensions and capacities, which will provide the best product available at the lowest possible price, other than designated brands and/or models approved as equal to designated products shall receive equal consideration.
- 7. BRAND NAME REFERENCES:** Any catalog brand name or manufacturer's reference used in the bid invitation is descriptive only, not restrictive, and used to indicate the type and quality desired. Bids on brands of like nature and quality will be considered unless otherwise specified. If bidding on other than referenced specifications, the bid must show the manufacturer, brand or trade name, and other descriptions, and should include the manufacturer's illustrations and complete descriptions of the product offered. CAW reserves the right to determine whether a substitute offered is equivalent to and meets the standards of the item specified and may require the bidder to supply additional descriptive material. The bidder guarantees that the product offered will meet or exceed specifications identified in this bid invitation. If the bidder takes no exception to specifications or reference data in this bid, he will be required to furnish the product according to brand names, numbers, etc., as specified in the invitation.
- 8. GUARANTY:** When submitting an "Invitation to Bid", the bidder warrants to the Central Arkansas Water Commission (CAWC) by Central Arkansas Water (CAW) that the goods and materials covered by the bid are fit for the purpose intended, and they are goods and materials free from defects in material and workmanship under normal use and service. In addition, bidder must deliver new commodities of the latest design and model, unless otherwise specified in the "Invitation to Bid".

Guarantees and warranties should be submitted with the bid, as they may be considered in making an award.

- 9. SAMPLES:** Samples, when requested, must be furnished free of expense to CAW. Each sample should be marked with the bidder's name and address, bid number and item number. If samples are not destroyed during reasonable examination they will be returned at bidder's expense, if requested, within thirty days following the opening of bids. If

the bidder does not request the return of samples within thirty days of bid opening, they will become the property of CAW.

10. AMENDMENTS: THIS ITB MAY BE MODIFIED ONLY BY AMENDMENTS WRITTEN AND AUTHORIZED BY CENTRAL ARKANSAS WATER. Bidders are cautioned to ensure that they have received or obtained, and responded to, any and all amendments to the bid prior to submission. It is the responsibility of the vendor to check the Central Arkansas Water website, <http://www.carkw.com> for any and all addendums.

11. TAXES AND TRADE DISCOUNTS: Sales or Use Tax shall not be included in the bid price but must be added by the vendor to the invoice billing. Although Use Tax shall not be included in the bid, vendors must register and pay tax direct to the Arkansas State Revenue Department.

Discounts offered will be taken when CAW qualifies for such. The beginning date for computing discounts will be the date of invoice or the date of delivery and acceptance, whichever is later. **CAW' preferred payment term is 2%N10.**

12. BUSINESS, PROFESSIONAL AND OCCUPATIONAL LICENSE REQUIREMENT: All firms or individuals located or doing business in Arkansas are required to be licensed in accordance with the required state, local and county agencies.

13. SAFETY: All Contractors and subcontractors performing services for CAW are required to and shall comply with all Occupational Safety and Health Administration (OSHA), State and County Safety and Occupational Health Standards and any other applicable rules and regulations. Also, all Contractors and subcontractors shall be held responsible for the safety of their employees and any unsafe acts or conditions that may cause injury or damage to any persons or property within and around the work site under this Contract.

14. AWARD: Term Contract: A contract award will be issued to the successful bidder. It results in a binding obligation without further action by either party. This award does not authorize shipment. Shipment is authorized by the receipt of a purchase order from CAW. **Firm Contract:** A written purchase order authorizing shipment will be furnished to the successful bidder.

15. LENGTH OF CONTRACT: The invitation to bid will show the period of time the term contract will be in effect.

16. DELIVERY ON FIRM CONTRACTS: The invitation to bid will show the number of days to place a commodity in CAW's designated location under normal conditions. If the bidder cannot meet the stated delivery, alternate delivery schedules may become a factor in an award. CAW has the right to extend delivery if reasons appear valid. If the date is not acceptable, CAW may buy elsewhere, and any additional cost will be borne by the vendor.

17. DELIVERY REQUIREMENTS: No substitutions or cancellations are permitted without written approval of CAW. Delivery shall be made during normal work hours only 8:00 a.m. to 4:30 p.m., unless prior approval for other delivery has been obtained from CAW. Packing memoranda shall be enclosed with each shipment.

18. STORAGE: CAW is responsible for storage if the contractor delivers within the time required and the agency cannot accept delivery.

19. DEFAULT: Vendor has defaulted, by failing or refusing to perform or observe the terms, conditions or covenants in any resulting contract or any of the rules and regulations promulgated by CAW pursuant thereto or has wrongfully failed or refused to comply with the instructions of CAW and said default is not cured within fourteen (14) days of receipt of written notice by CAW to do so, or if by reason of the nature of such default, the same cannot be remedied within fourteen (14) days following receipt by Vendor of written demand from CAW to do so, Vendor fails to commence the remedy of such default within said fourteen (14) days following such written notice or having so commenced shall fail thereafter to continue with diligence the curing thereof (with Vendor having the burden of proof to demonstrate); (a) that the default cannot be cured within fourteen (14) days, and (b) that it is proceeding with diligence to cure said default, and such default will be cured within a reasonable period of time).

CANCELLATION FOR DEFAULT: CAW may cancel any resulting contract because of Vendor's default by giving Vendor fourteen (14) days advance written notice.

TERMINATION: Notwithstanding the foregoing and as supplemental and additional means of termination of any resulting contract under this Section, in the event that Vendor has frequently, regularly or repetitively defaulted in the performance of any of the covenants and conditions required to be kept and performed by Vendor, in the opinion of CAW and regardless of whether Vendor has corrected each individual condition of default, Vendor shall be deemed by CAW to be a "habitual violator," shall forfeit the right to any further notice or grace period to correct, and all of said

defaults shall be considered cumulative and collectively shall constitute a condition of irredeemable default. CAW shall thereupon issue Vendor a final warning citing the circumstances therefore, and any single default by Vendor of whatever nature, subsequent to the occurrence of the last of said cumulative defaults, CAW may terminate any resulting contract upon giving of written final notice to Vendor, such cancellation to be effective upon the date specified in CAW's written notice to Vendor, and all contractual payments due hereunder plus any and all charges and interest shall be payable to said date, and Vendor shall have no further rights hereunder and immediately upon the specified date in such final notice Vendor shall proceed to cease any further performance under any resulting contract and cooperate with CAW to turn over equipment, if any, and all records and service responsibility as otherwise required herein.

EFFECTIVE DATE: In the event of the aforesaid events specified in section 17, termination shall be effective upon the date specified in CAW's written notice to Vendor and upon said date any resulting contract shall be deemed immediately terminated and upon such termination all liability of CAW under any resulting contract to Vendor shall cease, and CAW shall have the right to call the performance bond (if required) and shall be free to negotiate with other Vendors for the goods and services requested in the ITB.

- 20. VARIATION IN QUANTITY:** CAW assumes no liability for commodities produced, processed or shipped in excess of the amount specified on the purchase order.
- 21. INVOICING:** The contractor shall be paid upon the completion of all of the following: (1) submission of an original and the specified number of copies of a properly itemized invoice showing the bid and purchase order numbers, where itemized in the invitation to bid, (2) delivery and acceptance of the commodities and (3) proper and legal processing of the invoice by CAW. Invoices must be sent to the address identified in the Invitation to Bid.
- 22. CAW PROPERTY:** Any specifications, drawings, technical information, dies, cuts, negatives, positives, data or any other commodity furnished to the contractor hereunder or in contemplation hereof or developed by the contractor for use hereunder shall remain property of CAW, be kept confidential, be used only as expressly authorized and returned at the contractor's expense to the F.O.B. point properly identifying what is being returned.
- 23. PATENTS OR COPYRIGHTS:** The contractor agrees to indemnify and hold CAW harmless from all claims, damages and costs including attorneys' fees, arising from infringement of patents or copyrights.
- 24. ASSIGNMENT:** Any contract entered into pursuant to this invitation to bid shall not be assignable nor the duties thereunder delegable by either party without the written consent of the other party of the contract.
- 25. OTHER REMEDIES:** In addition to the remedies outlined herein, the contractor and CW have the right to pursue any other remedy permitted by law or in equity.
- 26. DISCRIMINATION:** In the event a contract is entered into pursuant to the "Invitation to Bid", the Firm shall not discriminate against any qualified employee or qualified applicant for employment because of race, sex, color, creed, age, disability, veteran's status, national origin or ancestry, or any other protected category. The Firm must include in any and all subcontracts a provision similar to the above.
- 27. CONTINGENT FEE:** The bidder guarantees that he has not retained a person to solicit or secure this contract upon an agreement or understanding for a commission, percentage, brokerage or contingent fee, except for retention of bona fide employees or bona fide established commercial selling agencies maintained by the bidder for the purpose of securing business.
- 28. ANTITRUST ASSIGNMENT:** As part of the consideration for entering into any contract pursuant to this invitation to bid, the bidder named on the front of this invitation to bid, acting herein by the authorized individual or its duly authorized agent, hereby assigns, sells and transfers to CAW all rights, title and interest in and to all causes of action it may have under the antitrust laws of the United States or this state for price fixing, which causes of action have accrued prior to the date of this assignment and which relate solely to the particular goods or services purchased or produced by CAW pursuant to this contract.
- 29. TIE BID:** In determining the award of identical bids, the Purchasing Manager shall break the tie in the following manner: A drawing or the flip of a coin shall be used to determine the successful bidder. Tie bidders shall be invited to witness the tie breaking and at least one witness must be present to verify the results of the tie breaking and shall certify the results on the bid tabulation sheet.

30. CONSTRUCTION:

- a. When noted, the Contractor must supply CAW with evidence of having and maintaining proper and complete insurance, specifically Workman's Compensation Insurance in accordance with the laws of the State of Arkansas, Public Liability and Property Damage. All premiums and cost shall be paid by the Contractor. In no way will CAW be responsible in case of accident.
- b. When noted, a certified check or bid bond in the amount of 5% of total bid shall accompany bid.
- c. A Payment Bond equaling the total amount of any bid exceeding \$20,000.00 must be provided.
- d. A Performance Bond equaling the total amount of any bid exceeding \$20,000.00 must be provided for any contract for the repair, alteration or erection of any public building, public structure, or public improvement (pursuant to A.C.A. §18-44-503, §18-44-501 and §18-44-506 as amended).

31. LIQUIDATED DAMAGES: Shall be assessed beginning on the first day following the maximum delivery or completion time entered on the bid form and/or provided for by the plans and specifications.

32. SEVERABILITY: If any provision of this Contract shall be declared illegal, void, or unenforceable by a court of competent jurisdiction, the other provisions shall not be affected but shall remain in full force and effect.

33. MINORITY BUSINESS POLICY: Central Arkansas Water encourages participation of disadvantaged, small, minority, and woman owned business enterprises in the procurement of goods, services, professional services, and construction, either as a general contractor or sub-contractor. It is further requested that whenever possible, prime contractors who require sub-contractors, seek qualified small, minority, and woman owned business to partner with them.

34. ALTERATION OF ORIGINAL ITB DOCUMENTS: The original written or electronic language of the ITB documents shall not be changed or altered except by approved written addendum issued by Central Arkansas Water. This does not eliminate a Bidder from taking exception(s) to non-mandatory terms and conditions but does clarify that the Bidder cannot change the original document's written or electronic language. If the Bidder wishes to make exception(s) to any of the original language, it must be submitted by the Bidder in separate written or electronic language in a manner that clearly explains the exception(s). If Bidder's/Contractor's submittal is discovered to contain alterations/changes to the original written or electronic documents, the Bidder's response may be declared as non-responsible, and the response shall not be considered.

35. CURRENCY: All bid pricing must be United States dollars and cents.

36. LANGUAGE: Bids will only be accepted in the English language.

37. NOTICES: Any notice, demand, communication, or request required or permitted hereunder shall be in writing, except where otherwise herein designated by telephone, and delivered in person or sent by certified, return receipt requested, United States Mail as follows:

Central Arkansas Water
Attn: CFO
221 East Capitol Avenue
Little Rock, Arkansas 72202

Notices shall be effective when received at the address as specified above. Changes in the respective address to which such notice shall be directed may be made from time to time by written notice. Facsimile transmission is acceptable notice, effective when received, however, facsimile transmissions received (*i.e.*, printed) after 4:30 p.m. or on weekends or holidays will be deemed received on the next business day. The original of items which are transmitted by facsimile equipment must also be mailed as required herein.

Attachment One

Specifications for One (1) Service Body and One (1) Undercarriage, PTO Driven Air Compressor

1. **Service Body** - The service body shall be a Model 6107BHC line body and CR107HC-H canopy roof as manufactured by Knapheide (or approved equal in all aspects) and shall be mounted on two (2) ton truck (extended cab chassis) as described in the attached specifications, (2022 Freightliner Model M2106). Central Arkansas Water will acquire the two-ton truck (extended cab chassis) on which the service body will be mounted in a separate sealed bid and delivered to the successful bidder.

2. **Dimensions and Materials**
 - 2.1. The body shall have an inside height of eighty-six (86) inches over the full walk area width
 - 2.2. Truck chassis shall be dual wheel with eighty-six (86) inch cab to axle length
 - 2.3. Body material shall be A60-U galvanized steel
 - 2.4. Body length shall be one hundred eight (108) inches
 - 2.5. Body Width shall be ninety-four (94) inches
 - 2.6. Floor Width shall be fifty-four (54) inches
 - 2.7. Compartment depth shall be twenty (20) inches
 - 2.8. Front compartment height shall be fifty (50) inches
 - 2.9. Rear compartment height shall be fifty (50) inches
 - 2.10. Floor to compartment top shall be twenty-nine (29) inches
 - 2.11. ALL body components i.e. load area; top; front & rear panels; bulkhead; front & rear partitions; front, horizontal & rear compartment floors and wheel panels shall be fourteen (14) gauge galvanized steel
 - 2.12. Flooring shall be twelve (12) gauge safety tread plate floor over four (4) inch structural steel channel cross members

3. **General Construction Methods**
 - 3.1. Body construction methods shall be such that bulkhead, front and rear panels shall be integrally welded to create/form a weather tight enclosure
 - 3.2. Door jams shall be "formed" to prevent water penetration into compartments
 - 3.3. Wheel radius shall be stamped
 - 3.4. Caulking around all seams/joints (interior and exterior) not welded i.e. around paddle latches, exterior seams, floor and compartment seams, underside of body, wheel area and perimeter of floor shall be SEKAFLEX 221
 - 3.5. Phosphatized spray shall be used throughout to etch surfaces prior to the priming process
 - 3.6. PPG polyurethane self-etch primer shall be applied under all hinges and add on exterior parts
 - 3.7. Service body shall be Single Stage OEM White Paint, (match color code of truck that body will be mounted on)
 - 3.8. Asphalt based undercoating shall be applied to the underside of the body and subframe
 - 3.9. Interior of service body shall have a Rhino, or equivalent, liner applied. It shall be white, (spray in only). It shall cover floor, walls, and shelving in line body area and exclude canopy portion and entry door (stop below seam between line body and canopy). It shall be a polyurethane non-skid coating with excellent impact, abrasion, corrosion, and chemical resistance.

4. **Door & Shelving - Materials and Construction Methods**
 - 4.1. Roll up rear door to fit 54" wide x 76. 27" tall clear door opening (heavy duty aluminum shutter type door) Gortite brand or equal
 - 4.2. All door hinge pins shall be 5/16-inch diameter, 304 stainless steel
 - 4.3. Hinge butts shall be zinc hinge block with neoprene inserts and mounted with zinc rivets
 - 4.4. Rain guards shall be sixteen (16) gauge galvanized steel
 - 4.5. Door supports shall incorporate cable with #60 horizontal "S" hooks
 - 4.6. Door latches shall be "paddle" type, blind mount, stainless steel and rotary locking
 - 4.7. Doors shall be of "double panel construction"
 - 4.8. Doors shall incorporate a continuous hinge with 5/16-inch 304 stainless steel pin roll formed into the outer panel
 - 4.9. The inner panel shall be formed with a ten (10) degree "over bend" to facilitate additional moisture protection
 - 4.10. Hinge butts shall be zinc with neoprene inserts to prevent binding
 - 4.11. Strikers shall be "double action" striker design
 - 4.12. Rain guards shall be incorporated on leading edge of all doors
 - 4.13. Automotive type door rubber shall be standard for door seals
 - 4.14. There shall be one (1) full length divider shelves in each side
 - 4.15. There shall be "retainer" rails on compartment tops

- 4.16. Shelving material for adjustable shelves, fixed shelves and divider trays shall be eighteen (18) gauge galvanized steel
- 4.17. Shelving material for adjustable shelf brackets and fixed shelf brackets shall be sixteen (16) gauge galvanized steel
- 4.18. Divider strips may be extruded plastic

5. Enclosing Materials and Supports

- 5.1. Top enclosing materials shall be as follows; sides, roof, bulkhead and shelving shall be sixteen (16) gauge galvanized steel
- 5.2. Front end panels, rear end panels and rear header shall be fourteen (14) gauge galvanized steel
- 5.3. The interior of this enclosed service body shall be lighted by two (2) permanently mounted, LED "dome" lights controlled from a switch permanently mounted at the rear doors. There shall be no vents installed in service body

6. Base Body

6.1. Right Side

- 6.1.1. First vertical (front) shall be fifty (50") inches high by twenty-eight and one-quarter (28 ¼") inches wide with two (2) adjustable divider shelves
- 6.1.2. Second vertical (middle) shall be fifty (50) inches high by twenty-five (25") inches wide with two (2) adjustable divider shelves
- 6.1.3. Horizontal shall be twenty-two and one-half (22 ½") inches high by fifty-four (54") inches wide with one (1) centered divider shelf. The floor of this compartment shall incorporate divider trays with five (5) extruded plastic adjustable dividers

6.2. Left Side

- 6.2.1. First vertical (front) shall be fifty (50") inches high by twenty-eight and one-quarter (28 ¼") inches wide with two (2) adjustable divider shelves
- 6.2.2. Second vertical (middle) shall be fifty (50) inches high by twenty-five (25") inches wide with two (2) adjustable divider shelves
- 6.2.3. Horizontal shall be twenty-two and one-half (22 ½") inches high by fifty-four (54") inches wide with one (1) centered divider shelf. The floor of this compartment shall incorporate divider trays with five (5) extruded plastic adjustable dividers

7. Cooling Fan Housing

- 7.1.1. A support structure for housing the cooling fan for the air compressor shall be made into the top of the service body extending over the truck cab. A removable protective cage shall be constructed around the cooling fan to protect it from low hanging limbs but still allow proper air flow. All housing structure components that require any drill or cut-out holes in service body shall be completely sealed to prevent moisture from entering body

8. Rear Bumper and Accessories

- 8.1.1. A Buyers Products PH30, (or equivalent), pintle hook with a minimum rating of 60,000 lbs. MGTW/ 15,000 lbs. MVL shall be installed on a hitch plate on rear bumper with stairs, (catwalk), on each side and built and reinforced to meet the pintle hook ratings. Entire bumper shall also be re-enforced so as not to bend, flex, or warp when stepping on the ends of bumper or when torquing something in vice at end of bumper. Cup of pintle shall be 25" from ground.
- 8.1.2. Both stair sets shall have a crafted, heavy duty, grip strut, fold down step with 400 lb. minimum capacity. Steps shall be designed to fold up and pin in place for travel and fold down for use. Grip strut area shall be width of catwalk steps and 12" deep minimum
- 8.1.3. Surface on top of bumper and steps, (including fold down step), shall be heavy duty Grip Strut for traction (3' deep bumper).
- 8.1.4. Bumper, hitch plate shall have a Rhino type liner applied. It shall be black, (spray in only). It shall cover all areas of bumper except rails. It shall be a polyurethane non-skid coating with excellent impact, abrasion, corrosion, and chemical resistance.
- 8.1.5. Safety handrails shall be installed across back of bumper and angled along steps. Rails shall be designed to pull up and swing out and be removable, (yellow in color)
- 8.1.6. Pintle shall be attached to hitch plate with ¾" grade 8 bolts.
- 8.1.7. Trailer air hose connections shall be installed on bumper above pintle hook and shall include Phillips #12-0100 11400, or equivalent, shut-off dummy glad-hands
- 8.1.8. A Balkamp, (or equivalent), Sure Lok 6 pole, round electrical connection for trailer shall be installed in bumper, over pintle hook (No 7-pole needed)
- 8.1.9. A Ridgid BC 410 bench chain vise shall be installed on drivers side end of

- Hog box on rear bumper (elevated to match height of grip strut)
- 8.1.10. 2 – 1" D-rinds shall be installed on hitch plate for trailer safety chains
- 8.1.11. 2 hand grabs shall be installed on each side of back of service body to aid in climbing up and down cat walk steps
9. **Lighting**
- 9.1.1. All exterior and interior lighting shall be LED
- 9.1.2. A 240HSFL Star Halo, (or equivalent), LED Beacon shall be installed on top of service body at front, drivers side corner and one at rear, passengers side corner
- 9.1.3. 2 adjustable work lights, (Nilight 6.5", 36W LED Flood Light Bar – or equal), shall be mounted on rear of service body on each side of door at top. They shall operate from the same light switch as the service body dome lights
10. **Air Compressor**
- 10.1.1. **Air compressor shall be provided and installed by the service body installer.** It shall be a Van Air Underdeck PTO Driven Air Compressor, Model UDSC4, (or equivalent), with 185 cfm @ 100 psi. All compressor components that require any drill or cut-out holes in service body shall be completely sealed to prevent moisture from entering body
11. **Air Tool, (Hole Hog), Compartment**
- 11.1.1. A container for a hole hog shall be constructed from 6" x 6" x 1/4" hot rolled steel. It shall be same width as rear bumper with hinged, lockable steel flaps on each end. Flap shall close upward where lock will be on top. Container shall be mounted across rear of hitch plate and lowered from top of hitch plate enough to allow grip strut to be added to walk area on top of hog box at same level as deck Grip strut. Hog box shall have extensions between the hog box and grip strut to allow for washing debris out of grip strut. Container shall be same black Rhino type coating (same as bumper, deck, steps and hitch plate)
12. **Ladder Racks**
- 12.1.1. Body shall be up fitted with 4 exterior ladder racks. Ladder racks shall be sealed against service body with rubber or other appropriate product to prevent moisture from entering body. Ladder rest shall be 16" above service body seam. White in color. See drawings "A" and "B"
13. **Pipe Racks**
- 13.1.1. Body shall be up fitted with 6 interior pipe racks. White in color. See drawings "A" and "B"
14. **Back-Up Alarm**
- 14.1.1. Balkamp (BK7301067), or equivalent, back-up alarm. 97 dB minimum, mounted inside truck frame near rear bumper.

(See Attached Drawings)

Ladder And Valve Key Racks

Ladder Racks (2 Left)
(Front and Rear)

Angle Iron 3" x 3" x 1/4"
Flat Bar 3" x 1/4"

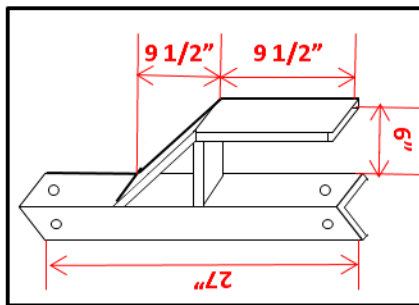

Ladder Racks (2 Right)
(Front and Rear)

Angle Iron 3" x 3" x 1/4"
Flat Bar 3" x 1/4"

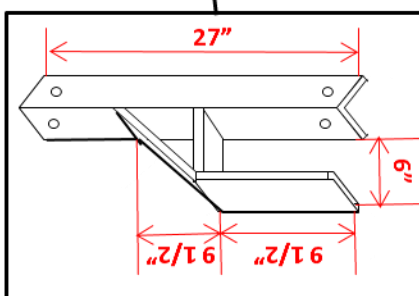

Tall Valve Key Racks (4)
(Front and Center)

Flat Bar 2 1/2" x 1/4"

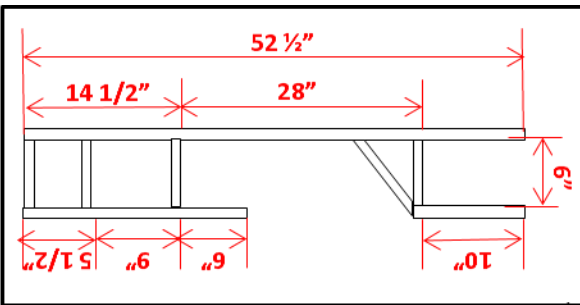

Short Valve Key Racks (2)
(Rear)

Flat Bar 2 1/2" x 1/4"

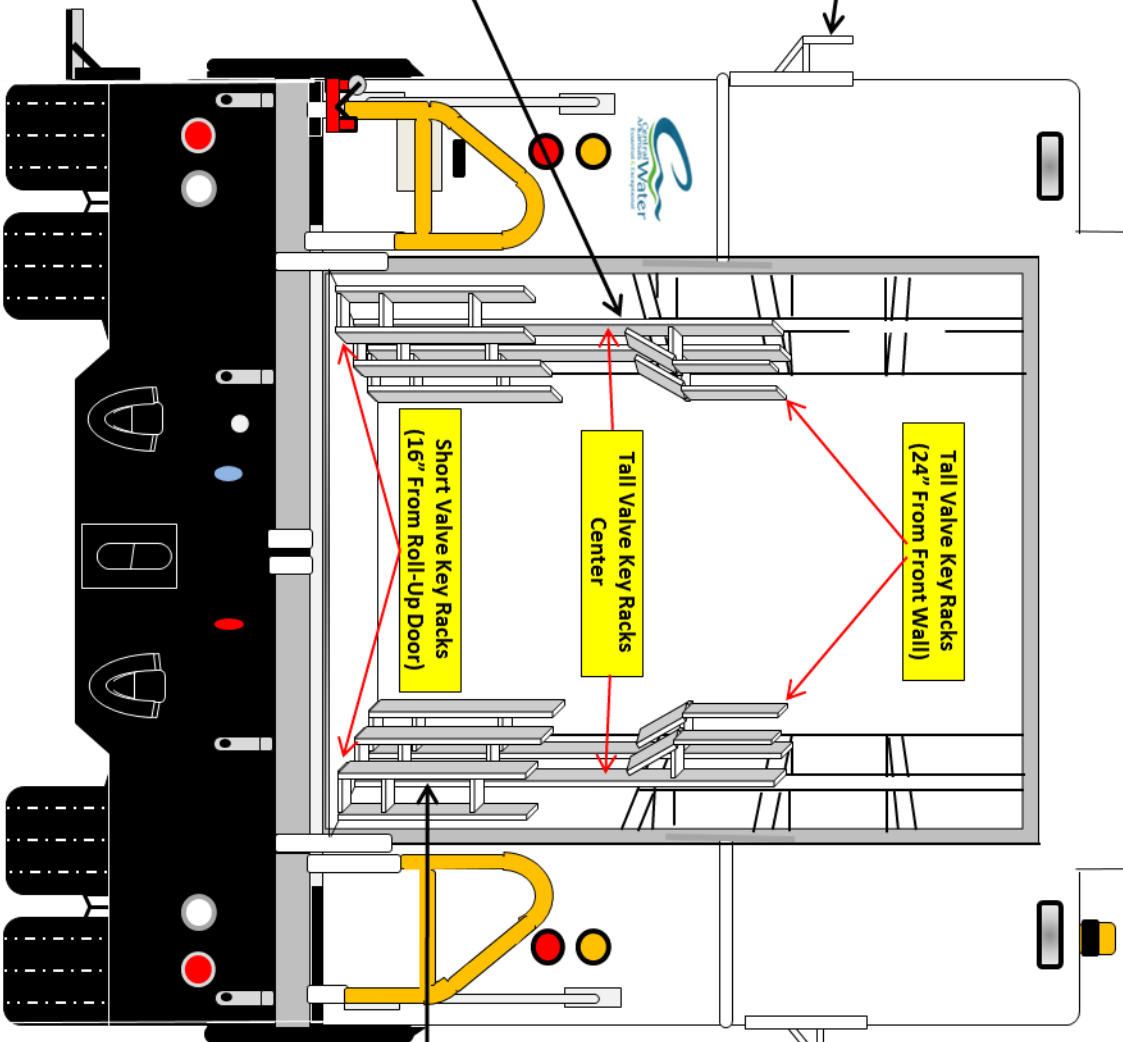
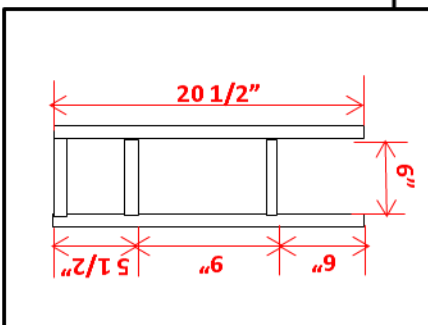

Note: If Service Body Floor Is Manufactured With Raised Areas For Fender Wells Adjustments Will Have To Be Made Accordingly On Center Valve Key Racks.